

IDEAL VT100WK

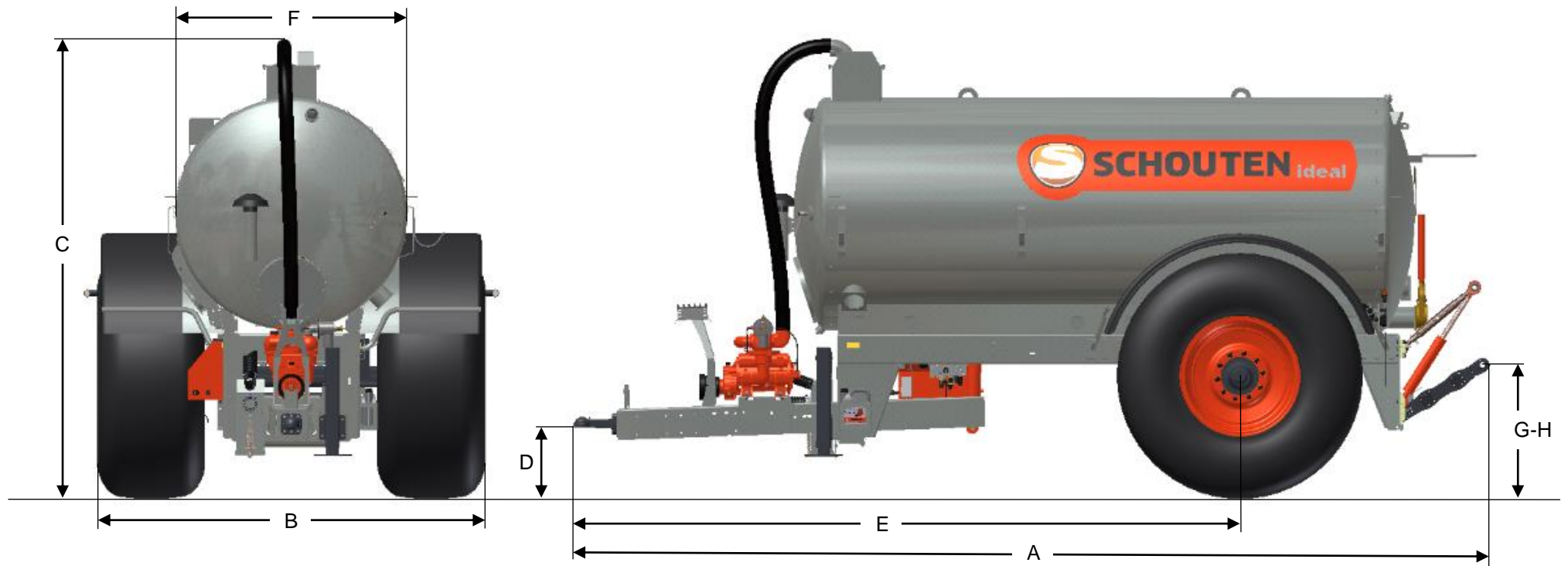

DIMENSIONS

A	LENGTH	6612 MM	E	DISTANCE HITCH - AXLE	4816 MM
B	WIDTH	2845 MM	F	TANK DIAMETER	1700 MM
C	HEIGHT	3400 MM	G	LIFT HEIGHT MIN.	235 MM
D	HITCH HEIGHT	400-700 MM	H	LIFT HEIGHT MAX.	990 MM

IDEAL VT100WK

MACHINE INFORMATION

TYPE	VT100WK
WEIGHT	3.120 KG
TANK DIMENSIONS	Ø1700X4040 MM
TANK VOLUME	10.000 L
LEVEL INDICATOR	FLOAT POINTER
UNDERCARRIAGE	SINGLE-AXLE
TYPE OF AXLE	BPW BRAKED □150MM
CARRYING CAPACITY AXLE	15.000 KG
TIRES	800/60R32

SUPPORT LEG	HYDR. DA
VACUUM PUMP	B&P MEC11000
CAPACITY VACUUM PUMP	11.137 L/MIN
VACUUM PUMP DRIVE	PTO 540/1000RPM
MOISTURE TRAP CAPACITY	15.500 L/MIN
LIFT POSSIBILITIES	GRASSLAND/BLACK SOIL
LIFT CAPACITY	3.500 KG
LIFT SYSTEM	4-POINT CAT III

OPTIONS

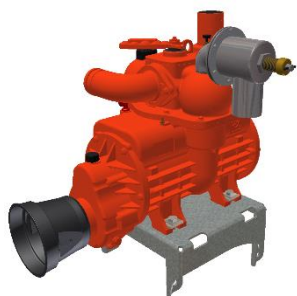

B&P MEC13500

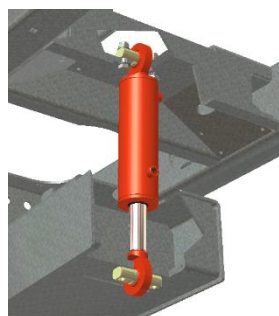

HYDR. DRAWBAR SUSPENSION

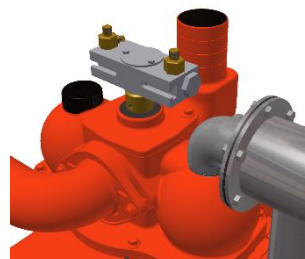

HYDR. PUMP SWITCHING



TURBO-FILLER 8-6



DOCKING FILLING ARM 8"